

GATE-2013 Aerospace Engineering (AE)

Aerospace Engineering (AE)

Q. 1 – Q. 25 carry one mark each.

1. The directional derivative of the function $f(x, y) = \frac{x^2 + xy^2}{\sqrt{5}}$ in the direction $\bar{a} = 2\hat{i} - 4\hat{j}$ at $(x, y) = (1, 1)$ is

- a) $-\frac{1}{\sqrt{5}}$
- b) $-\frac{2}{\sqrt{5}}$
- c) 0
- d) $-\frac{1}{5}$

2. The value of $\int_4^5 \frac{x+2}{x^2+4x-21} dx$ is

- a) $\ln \sqrt{24/11}$
- b) $\ln \sqrt{12/11}$
- c) $\ln \sqrt{2}$
- d) $\ln \left(\frac{12}{11}\right)$

3. At $x = 0$, the function $y = |x|$ is

- a) continuous but not differentiable
- b) continuous and differentiable
- c) not continuous but differentiable
- d) not continuous and not differentiable

4. One of the eigenvectors of the matrix

$$A = \begin{pmatrix} 1 & -1 & 0 \\ 0 & 1 & -1 \\ -1 & 0 & 1 \end{pmatrix} \text{ is } V = \begin{bmatrix} 1 \\ 1 \\ 1 \end{bmatrix}$$

The corresponding eigenvalue is _____

5. Which one of the following is the most stable configuration of an airplane in roll?

- a) Sweep back, anhedral and low wing
- b) Sweep forward, dihedral and low wing
- c) Sweep forward, anhedral and high wing
- d) Sweep back, dihedral and high wing

-
6. Which one of the following flight instruments is used on an aircraft to determine its attitude in flight?
- a) Vertical speed indicator
 - b) Altimeter
 - c) Artificial Horizon
 - d) Turn-bank indicator
7. A supersonic airplane is expected to fly at both subsonic and supersonic speeds during its whole flight course. Which one of the following statements is TRUE?
- a) Airplane will experience less stability in pitch at supersonic speeds than at subsonic speeds
 - b) Airplane will feel no change in pitch stability
 - c) Airplane will experience more stability in pitch at supersonic speeds than at subsonic speed
 - d) Pitch stability cannot be inferred from the information given
8. Which one of the following is favourable for an airplane operation?
- a) Tail wind in cruise and head wind in landing
 - b) Tail wind both in cruise and landing
 - c) Head wind both in cruise and landing
 - d) Head wind in cruise and tail wind in landing
9. Which one of the following is TRUE with respect to Phugoid mode of an aircraft?
- a) Frequency is directly proportional to flight speed
 - b) Frequency is inversely proportional to flight speed
 - c) Frequency is directly proportional to the square root of flight speed
 - d) Frequency is inversely proportional to the square root of flight speed
10. The x and y velocity components of a two-dimensional flow field are, $u = \frac{cy}{x^2+y^2}$, $v = \frac{cx}{x^2+y^2}$ where c is constant. The streamlines are a family of
- a) hyperbolas
 - b) parabolas
 - c) ellipses
 - d) circles
11. Which one of the following statements is NOT TRUE for a supersonic flow?
- a) Over a gradual expansion, entropy remains constant
 - b) Over a sharp expansion corner, entropy can increase
 - c) Over a gradual compression, entropy can remain constant
 - d) Over a sharp compression corner, entropy increases

12. Consider a compressible flow where an elemental volume of the fluid is $\delta\vartheta$ moving with Velocity \vec{V} . Which one of the following expressions is TRUE?

- a) $\nabla \cdot \vec{V} = \frac{1}{\delta\vartheta} \frac{D\delta\vartheta}{Dt}$
- b) $\nabla \cdot (\nabla \times \vec{V}) = \frac{1}{\delta\vartheta} \frac{D\delta\vartheta}{Dt}$
- c) $\nabla \cdot \frac{D\vec{V}}{Dt} = \frac{1}{\delta\vartheta} \frac{D\delta\vartheta}{Dt}$
- d) $\vec{V} \cdot (\nabla \times \vec{V}) = \frac{1}{\delta\vartheta} \frac{D\delta\vartheta}{Dt}$

GATE Aerospace Academy

13. Consider a thin flat plate airfoil at a small angle α to an oncoming supersonic stream of air.

Assuming the flow to be inviscid, $\frac{C_d}{C_l^2}$ is

- a) Zero
- b) independent of α
- c) proportional to α
- d) proportional to α^2

14. The critical Mach number for a flat plate of zero thickness, at zero angle of attack, is _____

15. A damped single degree-of-freedom system is vibrating under a harmonic excitation with an amplitude ratio of 2.5 at resonance. The damping ratio of the system is _____

16. The cross-section of a long thin-walled member is as shown in the figure. When subjected to pure

twist, point A



- a) does not move horizontally or axially, but moves vertically
- b) does not move axially, but moves both vertically and horizontally
- c) does not move horizontally, vertically or axially
- d) does not move vertically or axially, but moves horizontally

17. The channel section of uniform thickness 2mm shown in the figure is subjected to a torque of 10 Nm. If it is made of a material with shear modulus of 25 GPa, the twist per unit length in radians/m is _____

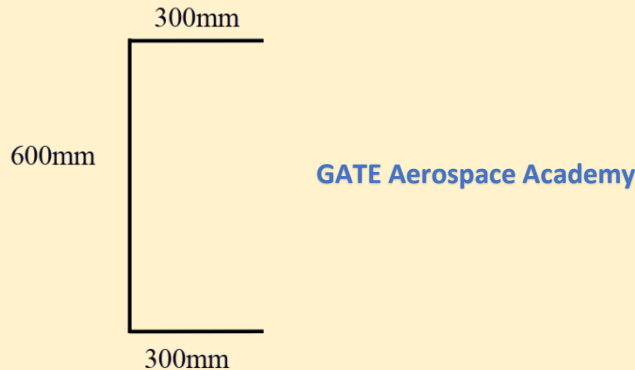

18. The stiffened cross-section of a long slender uniform structural member is idealized as shown in the figure below. The lumped areas at A, B, C and D have equal cross-sectional area of 3 cm^2 . The webs AB, BC, CD and DA are each 5 mm thick. The structural member is subjected to a twisting moment of 10 kNm. The magnitudes of the shear flow in the webs, q_{AB} , q_{BC} , q_{CD} , and q_{DA} in kN/m are, respectively

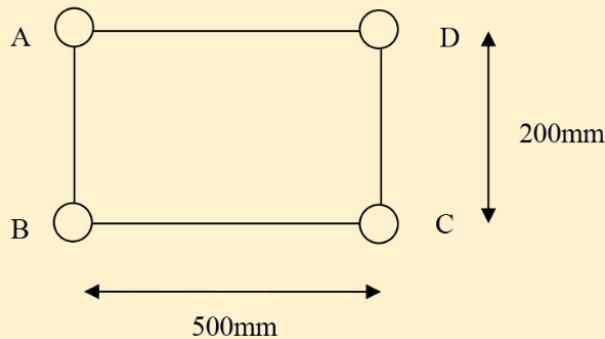

- a) 20, 20, 20, 20
 b) 0, 0, 50, 50
 c) 40, 40, 0, 0
 d) 50, 50, 50,
19. Consider two engines P and Q. In P, the high pressure turbine blades are cooled with a bleed of 5% from the compressor after the compression process and in Q the turbine blades are not cooled. Comparing engine P with engine Q, which one of the following is NOT TRUE?
- a) Turbine inlet temperature is higher for engine P
 b) Specific thrust is higher for engine P
 c) Compressor work is the same for both P and Q

-
- d) Fuel flow rate is lower for engine P
- 20.** The mass flow rate of air through an aircraft engine is 10 kg/s. The compressor outlet temperature is 400 K and the turbine inlet temperature is 1800 K. The heating value of the fuel is 42 MJ/kg and the specific heat at constant pressure is 1 kJ/kg-K. The mass flow rate of the fuel in kg/s is approximately _____
- 21.** For a given inlet condition, if the turbine inlet temperature is fixed, what value of compressor efficiency given below leads to the lowest amount of fuel added in the combustor of a gas turbine engine?
- a) 1
 - b) 0.95
 - c) 0.85
 - d) 0.8
- 22.** A gas turbine engine is mounted on an aircraft which can attain a maximum altitude of 11 km from sea level. The combustor volume of this engine is decided based on conditions at
- a) Sea Level
 - b) 8 Km altitude
 - c) 5.5 Km altitude
 - d) 11 Km altitude
- 23.** Consider the low earth orbit (LEO) and the geo synchronous orbit (GSO). Then
- a) ΔV requirement for launch to LEO is greater than that for GSO, and altitude of LEO is lower than that of GSO
 - b) ΔV requirement for launch to LEO is lower than that for GSO, and altitude of LEO is lower than that of GSO
 - c) ΔV requirement for launch to LEO is greater than that for GSO, and altitude of LEO is greater than that of GSO
 - d) ΔV requirement for launch to LEO is lower than that for GSO, and altitude of LEO is greater than that of GSO
- 24.** Which one of the following shows the CORRECT variation of stagnation temperature along the axis of an ideal ram jet engine?

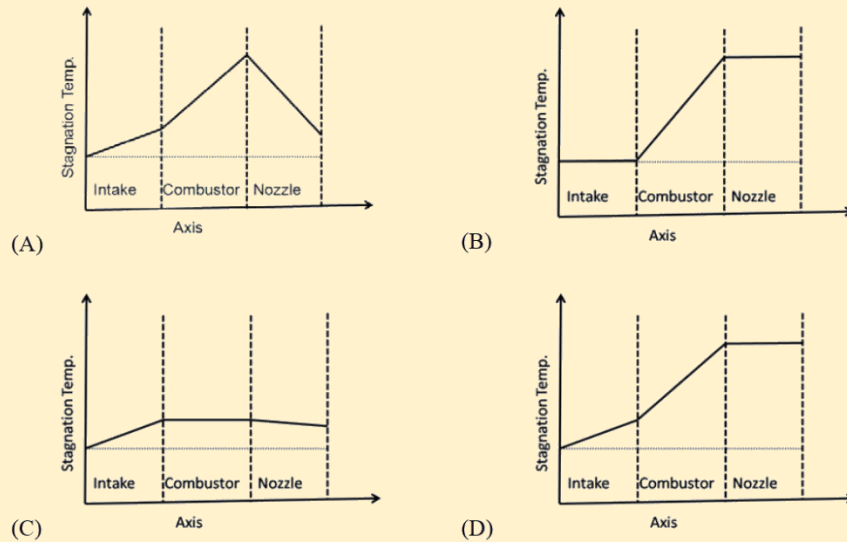

25. A rocket motor has a chamber pressure of 100 bar and chamber temperature of 3000 K. The ambient pressure is 1 bar. Assume that the specific heat at constant pressure is 1 kJ/kg-K. Also assume that the flow in the nozzle is isentropic and optimally expanded. The exit static temperature in K is

- a) 805
- b) 845
- c) 905
- d) 945

Q. 26 to Q. 55 carry two marks each.

26. Let $I = \iint_S (y^2 z \hat{i} + z^2 x \hat{j} + x^2 y \hat{k})(x \hat{i} + y \hat{j} + z \hat{k}) dS$, where S denotes the sphere of unit radius centered at the origin. Here \hat{i}, \hat{j} and \hat{k} denote the three orthogonal unit vectors. The value of I is _____

27. Given that the Laplace transform, $L(e^{at}) = \frac{1}{s-a}$ then $L(3e^{5t} \sinh 5t) =$

- a) $\frac{3S}{s^2-10s}$
- b) $\frac{15}{s^2-10s}$
- c) $\frac{3S}{s^2+10s}$
- d) $\frac{15}{s^2+10s}$

28. Values of a, b and c , which render the matrix

$$Q = \begin{bmatrix} \frac{1}{\sqrt{3}} & \frac{1}{\sqrt{2}} & a \\ \frac{1}{\sqrt{3}} & 0 & b \\ \frac{1}{\sqrt{3}} & -\frac{1}{\sqrt{2}} & c \end{bmatrix} \text{ orthonormal are, respectively}$$

- a) $\frac{1}{\sqrt{2}}, \frac{1}{\sqrt{2}}, 0$
- b) $\frac{1}{\sqrt{6}}, -\frac{2}{\sqrt{6}}, \frac{1}{\sqrt{6}}$
- c) $-\frac{1}{\sqrt{3}}, -\frac{1}{\sqrt{3}}, \frac{1}{\sqrt{3}}$
- d) $-\frac{1}{\sqrt{6}}, \frac{2}{\sqrt{6}}, -\frac{1}{\sqrt{6}}$

29. A function $y(t)$ satisfies the differential equation $\frac{d^2y}{dt^2} - 2\frac{dy}{dx} + y = 0$ and is subject to the Initial conditions $y(t=0) = 0$ and $\frac{dy}{dt}(t=0) = 1$. The value of $y(t=1)$ is
- a) e
 - b) 0
 - c) 1
 - d) -1

GATE Aerospace Academy

30. A glider is launched from a 500m high hilltop. Following data is available for the glider: Zero lift drag coefficient $C_{DO} = 0.02$, aspect ratio $AR = 10$ and Oswald efficiency factor $e = 0.95$. The maximum range of the glider in km is _____
31. Which one of the following criteria leads to maximum turn rate and minimum radius in a level turn flight?
- a) Highest possible load factor and highest possible velocity
 - b) Lowest possible load factor and lowest possible velocity
 - c) Highest possible load factor and lowest possible velocity
 - d) Lowest possible load factor and highest possible velocity
32. Consider an airplane with rectangular straight wing at dihedral angle $\Gamma = 10^\circ$. Lift curve slope of wing airfoil section (constant over the whole span of the wing) is $C_{l\alpha} = 5.4/rad$. The roll stability derivative, $C_{l\beta}$ in per radian is _____
33. Consider one-dimensional isentropic flow at a Mach number of 0.5. If the area of cross-section of a stream tube increases by 3% somewhere along the flow, the corresponding percentage change in density is _____

34. The potential flow model for a storm is represented by the superposition of a sink and a vortex.

The stream function can be written in the (r, θ) system as $\psi = \frac{\Lambda}{2\pi}\theta + \frac{\Gamma}{2\pi}\ln r$, where $\Lambda = \Gamma = 100 \text{ m}^2/\text{s}$. Assume a constant air density of 1.2 kg/m^3 . The gauge pressure at a distance of 100 m from the storm eye is

- a) $-\infty$
- b) $-\frac{1.2}{\pi^2}$
- c) $-\frac{1.2}{2\pi^2}$
- d) $-\frac{1.2}{4\pi^2}$

35. Three identical eagles of wing span s are flying side by side in a straight line with no gap between their wing tips. Assume a single horse shoe vortex model (of equal strength Γ) for each bird. The net downwash experienced by the middle bird is

- a) $\frac{\Gamma}{\pi S}$
- b) $\frac{\Gamma}{2\pi S}$
- c) $\frac{\Gamma}{3\pi S}$
- d) $\frac{4\Gamma}{3\pi S}$

GATE Aerospace Academy

36. Streamline pattern of flow past a cylinder is shown in the figure below. The oncoming flow is steady, irrotational and incompressible. The flow is from left to right. Bernoulli's equation CANNOT be applied between the points

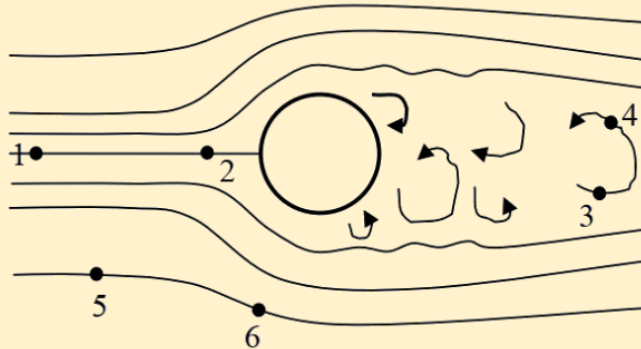

- a) 1 and 2
- b) 1 and 5
- c) 3 and 4
- d) 5 and 6

37. Consider a supersonic stream at a Mach number $M=2$, undergoing a gradual expansion. The stream is turned by an angle of 3 degrees due to the expansion. The following data is given.

M	ν (Prandtl -Meyer function)
1.8	20.73
1.9	23.59
2.0	26.38
2.1	29.10
2.2	31.73
2.3	34.28
2.4	36.75

The Mach number downstream of the expansion is

- a) 1.88
- b) 2.00
- c) 2.11
- d) 2.33

38. The idealized cross-section of a beam is comprised of four identical booms connected by shear webs. The beam is subjected to a bending moment M as shown in the figure. The inclination of the neutral axis to the x-axis in degrees is

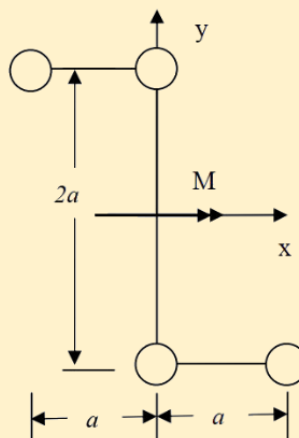

- a) 45 CW
- b) 45 CCW
- c) 26.6 CW
- d) 63.4 CCW

39. A composite circular shaft is comprised of a steel core surrounded by an aluminium annulus, perfectly bonded to each other as shown in the figure. If it subjected to a pure torque, which one of the following statements is TRUE?

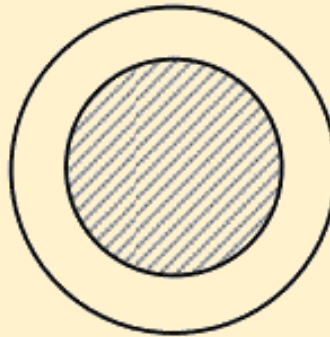

- a) Only shear stress is continuous across the steel–aluminium interface
 - b) Only shear strain is continuous across the steel–aluminium interface
 - c) Both shear stress and shear strain are continuous across the steel–aluminium interface
 - d) Both shear stress and shear strain are discontinuous across the steel–aluminium interface
40. A horizontal rectangular plate ABCD is hinged at points A, B and C. AC and BD are diagonals of the plate. Downward force P is applied at D. The upward reactions $R_A, R_B, \text{ and } R_C$ at points A, B and C, respectively, are
- a) indeterminate
 - b) $P, -P, P$
 - c) $0, P, 0$
 - d) $P/3, P/3, P/3$
41. In the steel structure (Young's modulus = 200 GPa) shown in the figure, all members have a circular cross-section of radius 10 mm. Column BD is pinned at B and D. The support at A is hinged. The minimum value of load at which the column BD may buckle in Newtons is approximately _____

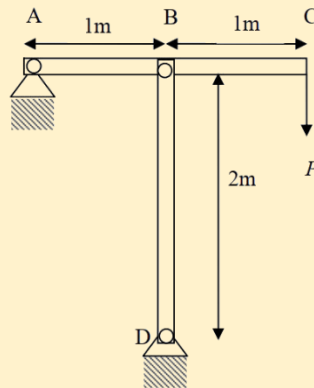

42. The thin rectangular plate has dimensions $L \times b \times t$. It develops a stress field corresponding to an applied bending moment M as shown in the figure. A valid Airy's stress function is

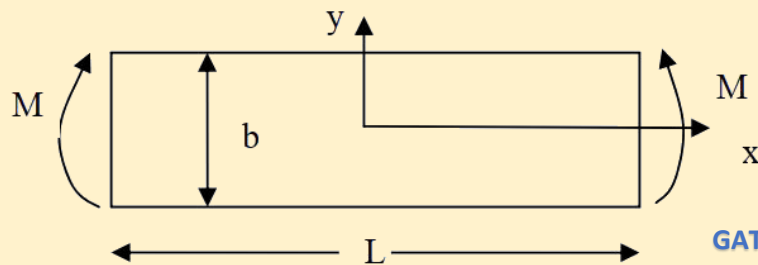

- a) $\frac{2M}{tb^3}x^3$
 b) $\frac{2M}{tb^3}y^3$
 c) $\frac{2M}{tb^3}(x^3 + y^3)$
 d) $\frac{2M}{tb^3}y^4$

43. A cantilever beam of negligible mass is 0.6 m long. It has a rectangular cross-section of width 8mm and thickness 6 mm and carries a tip mass of 1.4 kg. If the natural frequency of this system is 10 rad/s, young's modulus of the material of the beam in GPa is _____
44. A simply supported beam with overhang is loaded by uniformly distributed load of intensity q as shown in the figure. The bending moment at the mid-point of AB is

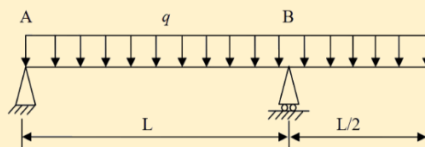

- a) $\frac{qL^2}{16}$ sagging
- b) $\frac{qL^2}{16}$ hogging
- c) $\frac{3qL^2}{16}$ hogging
- d) $\frac{3qL^2}{16}$ hogging

45. Thrust of liquid oxygen - liquid hydrogen rocket engine is 300 kN. The O/F ratio used is 5. If the fuel mass flow rate is 12.5 kg/s, the specific impulse of the rocket motor in Ns/kg is
- a) 3800
 - b) 4000
 - c) 4200
 - d) 4400
46. In a 50 % reaction axial compressor stage, the local blade velocity is 300 m/s and the axial component of velocity is 100 m/s. If the absolute inlet flow angle $\alpha_1 = 45^\circ$, the work per unit mass done on the fluid by the stage in kJ/kg is
- a) 30
 - b) 40
 - c) 50
 - d) 60
47. Consider two rockets P and Q fired vertically up with identical specific impulse and a payload of 2 kg. Rocket P has 2 identical stages, and each stage has 200 kg of propellant and 20 kg of structural weight. Rocket Q has a single stage with 400 kg of propellant and 40 kg of structural weight. Neglecting drag and gravity effects, the ratio of the change in velocity of P to that attained by Q is
- a) 1.13
 - b) 1.23
 - c) 1.33
 - d) 1.43

GATE Aerospace Academy

Common Data Questions

Common Data for Questions 48 and 49:

Data for an airplane are given as follows: weight $W=30\text{kN}$, thrust available at sea-level

$T_0 = 4000N$, wing planform area $S = 30 \text{ m}^2$, maximum lift coefficient $C_{L,max} = 1.4$, and drag coefficient $C_D = 0.015 + 0.024 C_L^2$ Assume air density at sea-level $\rho_\infty = 1.22 \text{ kg/m}^3$

48. Stall speed of the airplane in m/s is

- a) 17.36
- b) 34.22
- c) 45.52
- d) 119.46

49. Minimum and maximum speeds of the airplane in level flight condition at sea-level in m/s are Respectively

- a) 17.36 and 180
- b) 17.36 and 34.22
- c) 34.22 and 119.46
- d) 17.36 and 119.46

Common Data for Questions 50 and 51: An aircraft is flying at Mach number $M = 1.5$, where the ambient temperature is 250 K. The stagnation temperature of gases at the entry to the nozzle is 800 K. The nozzle is choked and always under expanded. Assume the molecular weight of the exhaust gases to be 29, the ratio of specific heats to be 1.4 and the universal gas constant is 8314 J/kmol-K.

50. For which one of the nozzle exit Mach numbers given below is the propulsive efficiency highest?

- a) 1
- b) 1.5
- c) 2
- d) 2.5

51. For which one of the nozzle exit Mach numbers given below is the thrust highest?

- a) 1
- b) 1.5
- c) 2
- d) 2.5

Linked Answer Questions

Statement for Linked Answer Questions 52 and 53: Circulation theory of lift is assumed for a thin symmetric airfoil at an angle of attack α . Free stream velocity is U .

52. If the circulation at the quarter chord ($c/4$) of the airfoil is Γ_1 , the normal velocity is zero at
- $c/4$
 - $c/2$
 - $3c/4$
 - All points on the chord
53. A second identical airfoil is placed behind the first one at a distance of $c/2$ from the trailing edge of the first. The second airfoil has an unknown circulation Γ_2 placed at its quarter chord. The normal velocity becomes zero at the same chord-wise locations of the respective airfoils as in the previous question. The values of Γ_1 and Γ_2 are respectively
- $\frac{4}{3}\pi cU\alpha, \frac{2}{3}\pi cU\alpha$
 - $\frac{2}{3}\pi cU\alpha, \frac{2}{3}\pi cU\alpha$
 - $\frac{2}{3}\pi cU\alpha, \frac{1}{3}\pi cU\alpha$
 - $\frac{4}{3}\pi cU\alpha, \frac{4}{3}\pi cU\alpha$

Statement for Linked Answer Questions 54 and 55: A wing-body alone configuration airplane with a wing loading of $W/S = 1000 \text{ N/m}^2$ flying in cruise condition at a speed $V = 90 \text{ m/s}$ at sea-level (air density at sea-level $\rho_\infty = 1.22 \frac{\text{kg}}{\text{m}^3}$). The zero lift pitching moment coefficient of the airplane is $C_{mac}^{wb} = C_{m0} = -0.06$ and the location of airplane aerodynamic center from the wing leading edge $X_{ac} = 0.25c$. Here c is the chord length

54. The airplane trim lift coefficient $C_{L \text{ trim}}$ is
- 0.502
 - 0.402
 - 0.302
 - 0.202
55. Distance of Centre of gravity of the aircraft (X_{CG}) from the wing leading edge is
- 0.447 c
 - 0.547 c
 - 0.547 c
 - 0.25 c

General Aptitude (GA) Questions

Q. 56 – Q. 60 carry one mark each.

56. If $3 \leq X \leq 5$ and $8 \leq Y \leq 11$ then which of the following options is TRUE?

- a) $\frac{3}{5} \leq \frac{X}{Y} \leq \frac{8}{5}$
b) $\frac{3}{11} \leq \frac{X}{Y} \leq \frac{5}{8}$
c) $\frac{3}{11} \leq \frac{X}{Y} \leq \frac{8}{5}$
d) $\frac{3}{5} \leq \frac{X}{Y} \leq \frac{8}{11}$

57. The headmaster _____ to speak to you

Which of the following options is incorrect to complete the above sentence?

- a) is wanting
b) wants
c) want
d) was wanting

58. Mahatma Gandhi was known for his humility as

- a) he played an important role in humiliating exit of British from India.
b) he worked for humanitarian causes.
c) he displayed modesty in his interactions.
d) he was a fine human being.

59.

All engineering students should learn mechanics, mathematics and how to do computation

I

II

III

IV

Which of the above underlined parts of the sentence is not appropriate?

(A) I

(B) II

(C) III

(D) IV

60. Select the pair that best expresses a relationship similar to that expressed in the pair

water: pipe:

- a) cart: road
b) electricity: wire
c) sea: beach
d) music: instrument

Q. 61 to Q. 65 carry two marks each.

61. Velocity of an object fired directly in upward direction is given by $V = 80 - 32t$, where t (time) is in seconds. When will the velocity be between 32 m/sec and 64 m/sec ?

- a) (1,3/2)
- b) (1/2,1)
- c) (1/2,3/2)
- d) (1,3)

62. In a factory, two machines M1 and M2 manufacture 60% and 40% of the auto components respectively. Out of the total production, 2% of M1 and 3% of M2 are found to be defective. If a randomly drawn auto component from the combined lot is found defective, what is the probability that it was manufactured by M2?

- a) 0.35
- b) 0.45
- c) 0.5
- d) 0.4

63. Following table gives data on tourists from different countries visiting India in the year 2011.

Country	Number of Tourists
USA	2000
England	3500
Germany	1200
Italy	1100
Japan	2400
Australia	2300
France	1000

Which two countries contributed to the one third of the total number of tourists who visited India in 2011?

- a) USA and Japan
- b) USA and Australia
- c) England and France
- d) Japan and Australia

64. If $|-2X + 9| = 3$ then the possible value of $|-X| - X^2$ would be:

- a) 30
- b) -30
- c) -42
- d) 42

65. All professors are researchers

Some scientists are professors

Which of the given conclusions is logically valid and is inferred from the above arguments?

- a) All scientists are researchers
- b) All professors are scientists
- c) Some researchers are scientists
- d) No conclusion follows

END OF THE QUESTION PAPER

Download our App

Download application for free Test, Assignments, enquiries and other benefits. For Android, type **Gate Aerospace Academy** in google play store and get it.

<https://play.google.com/store/apps/details?id=co.lynde.izlcw>

For iOS contact personally (9000373757,8368433511)



Best GATE Aerospace classroom coaching, 230+ Test series, doubt support, application download

www.gateaerospaceacademy.com

Call: 9000373757,8368433511



Gate Aerospace 2022 Toppers

★★★★★

Hritam Nath

Amit Vashistha



All India Rank **(2)**

All India Rank **(6)**

25 AIR Krishna	36 AIR Manasa	42 AIR David	62 AIR Vishal	66 AIR Sahil	81 AIR Prutvi Raj	98 AIR Akhilesh	98 AIR Avishi	98 AIR Chouse	109 AIR Surya
118 AIR K somesh	134 AIR Sri Sai	140 AIR Spandan	148 AIR Bala V	162 AIR Bhagya Lakshmi	173 AIR Riya	189 AIR Ravi	226 AIR Megha	258 AIR Dhruv	328 AIR Dinesh
339 AIR Veesh	390 AIR Ritu Raj	404 AIR Pradeep	486 AIR Girish	626 AIR Mandeep					

HEARTY CONGRATULATIONS TO OUR STUDENTS FOR THEIR EXCEPTIONAL PERFORMANCE IN
GATE AEROSPACE 2021

05 AIR Raghnathan	10 AIR Vikrant	13 AIR Priywart	17 AIR Eshwar	23 AIR Sana	27 AIR Karthik	33 AIR Ratnaashree	37 AIR Thositha
39 AIR Mukesh	39 AIR Riya	39 AIR Shiva	47 AIR Shashank	47 AIR Surya	53 AIR Nandini	59 AIR Mayank	64 AIR K.Madhulaasa
89 AIR Vishnu	89 AIR Samridh	98 AIR Anubhav	118 AIR Pratyush	129 AIR Ranjith	134 AIR Shivam	152 AIR Vineeth	173 AIR Satvika



HEARTY CONGRATULATIONS TO OUR STUDENTS FOR THEIR EXCEPTIONAL PERFORMANCE IN
GATE AEROSPACE 2020

03 AIR MAHENDRA GEHLOT Gate Aerospace Academy	04 AIR SHYAM KUMAR Gate Aerospace Academy	10 AIR HARSHIL GOHEL Gate Aerospace Academy	31 AIR AISHWARYA Gate Aerospace Academy
34 AIR VIKAS Gate Aerospace Academy	40 AIR AKSHAY Gate Aerospace Academy	49 AIR SREE LEKSHMI Gate Aerospace Academy	51 AIR PANKAJ Gate Aerospace Academy
62 AIR RAGHVENDRA Gate Aerospace Academy	74 AIR KARTIK Gate Aerospace Academy	and many more...	

Best GATE Aerospace classroom coaching, 230+ Test series, doubt support, application download

www.gateaerospaceacademy.com

Call: 9000373757, 8368433511

02 AIR	31 AIR	36 AIR	51 AIR	75 AIR	81 AIR
95 AIR	100 AIR	128 AIR	138 AIR	151 AIR	155 AIR
168 AIR	175 AIR	198 AIR	230 AIR	242 AIR	
	245 AIR	247 AIR	260 AIR		



Gate
AeroSpace
2019
Results











Hearty congratulations to our Classroom Program student from Karunya Institute of Technology and Sciences for his extraordinary performance in Gate Aerospace 2021



AIR-13
PRIYWART KHATRI

www.gateaerospaceacademy.com

Hearty congratulations to our Classroom Program students from Rajasthan Technical University Kota for their extraordinary performance in Gate Aerospace 2021

			
AIR-10	AIR-39	AIR-59	AIR-98
VIKRANT VASHISTHA	MUKESH GOKLANI	MAYANK AGARWAL	ANUBHAV JOSHI

www.gateaerospaceacademy.com

Hearty congratulations to our Classroom Program students for their extraordinary performance in Gate Aerospace 2021

		
AIR-47	AIR-39	AIR-47
M.SURYA REVA UNIVERSITY BANGALORE	RIYA PATEL APOLLO INSTITUTE OF ENGINEERING	SHASHANK KUMAR AMITY UNIVERSITY NOIDA



www.gateaerospaceacademy.com

Hearty congratulations to our Classroom Program students from Institute of Aeronautical Engineering college for their extraordinary performance in Gate Aerospace 2021

		
AIR-39	AIR-64	AIR-152
M.SHIVA TEJA REDDY	K.MADHULAALASA	P.VINEETH

www.gateaerospaceacademy.com

Hearty congratulations to our Classroom Program students for their extraordinary performance in Gate Aerospace 2021

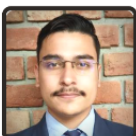
		
AIR-53	AIR-89	AIR-89
NANDINI JAIN SRM INSTITUTE OF TECHNOLOGY, CHENNAI	M.VISHNU TEJA MANIPAL INSTITUTE OF TECHNOLOGY, MANIPAL	SAMRIDH PATIAL UNIVERSITY OF PETROLEUM AND ENERGY STUDIES, DEHRADUN

www.gateaerospaceacademy.com

HEARTY CONGRATULATIONS TO OUR STUDENT K SWARNASHEE FOR SELECTING AS A JUNIOR RESEARCH FELLOWSHIP AT DRDO



K.Swarnashree

www.gateaerospaceacademy.com

Our gallery



Best GATE Aerospace classroom coaching, 230+ Test series, doubt support, application download

www.gateaerospaceacademy.com

Call: 9000373757, 8368433511





Our Books

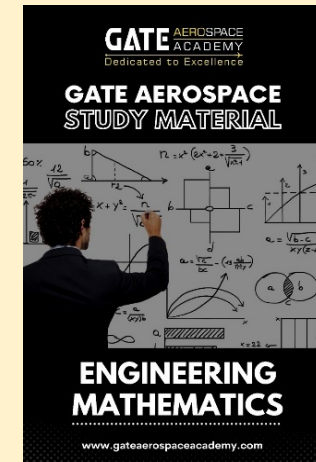

Best GATE Aerospace classroom coaching, 230+ Test series, doubt support, application download

www.gateaerospaceacademy.com

Call: 9000373757, 8368433511